

400mA Micropower Synchronous Step-Up DC/DC Converter with Output Disconnect

FEATURES

- Up to 95% Efficiency
- Output Disconnect and Inrush Current Limit
- Fixed Output Voltages of 3V, 3.3V or 5V
- Delivers 65mA at 3V from a 1V Input
- Delivers 60mA at 3.3V from a 1V Input, or 140mA at 3.3V from a 1.8V Input
- Delivers 175mA at 5V from a 3V Input
- Burst Mode® Operation: $I_Q = 7\mu A$
- Only Three External Components
- $V_{IN} > V_{OUT}$ Operation
- $<1\mu A$ Shutdown Current
- Antiringing Control
- Short-Circuit and Overtemperature Protection
- Very Low Profile of 1mm
- Tiny 6-Lead SC70 Package

APPLICATIONS

- MP3 Players
- Portable Instruments
- Glucose Meters
- Digital Cameras

LT, LT, LTC, LTM, Burst Mode, Linear Technology and the Linear logo are registered trademarks and ThinSOT is a trademark of Linear Technology Corporation. All other trademarks are the property of their respective owners. Patents pending.

DESCRIPTION

The LTC®3525-3/LTC3525-3.3/LTC3525-5 are high efficiency synchronous step-up DC/DC converters with output disconnect that can start up with an input as low as 0.85V. They offer a compact, high efficiency alternative to charge pumps in single cell or dual cell alkaline or Li-Ion applications. Only three small external components are required. The LTC3525 is offered in fixed output voltages of 3V, 3.3V or 5V.

The device includes a 0.5Ω N-channel MOSFET switch and a 0.8Ω P-channel synchronous rectifier. Peak switch current ranges from 150mA to 400mA, depending on load, providing enhanced efficiency. Quiescent current is an ultralow $7\mu A$, maximizing battery life in portable applications.

Other features include $<1\mu A$ shutdown current, antiringing control and thermal shutdown. The LTC3525 is available in a tiny 6-Lead SC70 package.

List of LTC3525 Options

PART NAME	INPUT START-UP VOLTAGE	OUTPUT VOLTAGE	V _{OUT} STATUS IN SHUTDOWN MODE
LTC3525-3	0.85V	3V	Output Disconnect
LTC3525-3.3	0.85V	3.3V	Output Disconnect
LTC3525-5	0.85V	5V	Output Disconnect
LTC3525D-3.3	0.85V	3.3V	Pass Through Mode
LTC3525L-3	0.7V	3V	Output Disconnect

TYPICAL APPLICATION

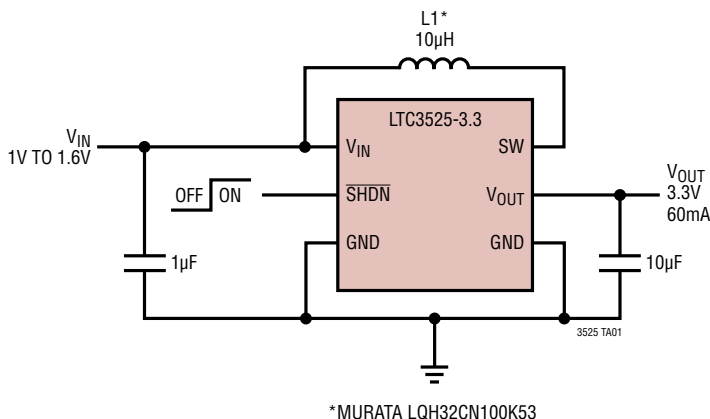

LTC3525-3.3 Efficiency and Power Loss vs Load Current

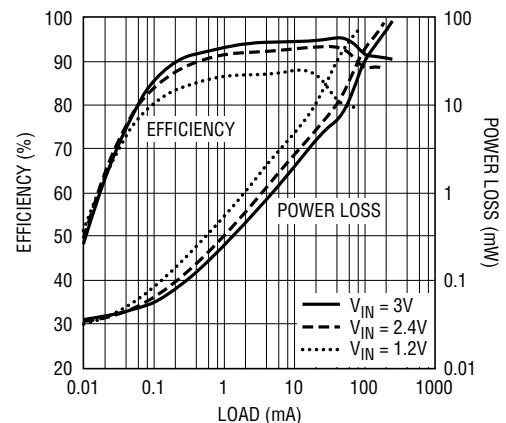

LT3525 - TA02

3525fc

LTC3525-3/ LTC3525-3.3/LTC3525-5

ABSOLUTE MAXIMUM RATINGS

(Note 1)

V_{IN} , V_{OUT} Voltage	-0.3V to 6V
SW Voltage	-0.3V to 6V
SW Voltage < 100ns.....	-0.3V to 7V
SHDN Voltage	-0.3V to 6V
Operating Junction Temperature Range (Notes 2, 5).....	-40°C to 125°C
Storage Temperature Range	-65°C to 125°C
Lead Temperature (Soldering, 10 sec).....	300°C

PIN CONFIGURATION

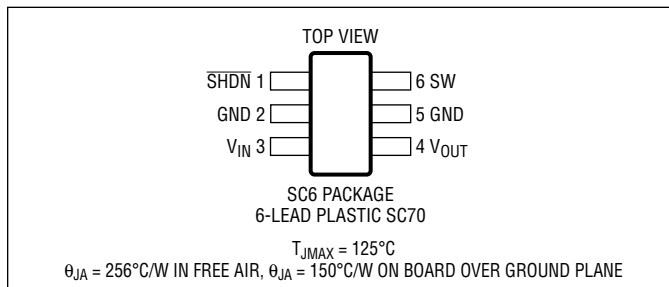

ORDER INFORMATION

LEAD FREE FINISH	TAPE AND REEL	PART MARKING	PACKAGE DESCRIPTION	TEMPERATURE RANGE
LTC3525ESC6-3#PBF	LTC3525ESC6-3#TRPBF	LCDR	6-Lead Plastic SC70	-40°C to 85°C
LTC3525ISC6-3#PBF	LTC3525ISC6-3#TRPBF	LCDR	6-Lead Plastic SC70	-40°C to 125°C
LTC3525ESC6-3.3#PBF	LTC3525ESC6-3.3#TRPBF	LBTG	6-Lead Plastic SC70	-40°C to 85°C
LTC3525ISC6-3.3#PBF	LTC3525ISC6-3.3#TRPBF	LBTG	6-Lead Plastic SC70	-40°C to 125°C
LTC3525ESC6-5#PBF	LTC3525ESC6-5#TRPBF	LBWT	6-Lead Plastic SC70	-40°C to 85°C
LTC3525ISC6-5#PBF	LTC3525ISC6-5#TRPBF	LBWT	6-Lead Plastic SC70	-40°C to 125°C

Consult LTC Marketing for parts specified with wider operating temperature ranges.

Consult LTC Marketing for information on non-standard lead based finish parts.

For more information on lead free part marking, go to: <http://www.linear.com/leadfree/>

For more information on tape and reel specifications, go to: <http://www.linear.com/tapeandreeel/>

ELECTRICAL CHARACTERISTICS (LTC3525-3)

The ● denotes the specifications which apply over the full operating junction temperature range, otherwise specifications are at $T_A = 25^\circ\text{C}$. $V_{IN} = 1.2\text{V}$, $V_{\overline{\text{SHDN}}} = 1.2\text{V}$, $V_{OUT} = 3\text{V}$ unless otherwise noted. (Note 2)

PARAMETER	CONDITIONS		MIN	TYP	MAX	UNITS
Input Start-Up Voltage				0.85	1	V
Output Voltage	(Note 6)	●	2.91	3.00	3.09	V
Quiescent Current, V_{OUT}	$\overline{\text{SHDN}} = V_{IN}$ (Note 4)			7	15	μA
Quiescent Current, V_{IN}	$\overline{\text{SHDN}} = V_{IN}$ (Note 4)			0.5	3	μA
Quiescent Current, V_{IN} – Shutdown	$\overline{\text{SHDN}} = 0\text{V}$, $V_{OUT} = 0\text{V}$ Not Including Switch Leakage			0.1	1	μA
NMOS Switch Leakage Current	$V_{IN} = V_{OUT} = V_{SW} = 5\text{V}$, $\overline{\text{SHDN}} = 0\text{V}$			0.1	1	μA
PMOS Switch Leakage Current	$V_{IN} = V_{SW} = 5\text{V}$, $V_{OUT} = 0\text{V}$, $\overline{\text{SHDN}} = 0\text{V}$			0.1	3	μA
NMOS Switch On-Resistance	(Note 3)			0.6		Ω
PMOS Switch On-Resistance	(Note 3)			0.9		Ω
Peak Current Limit			0.4	0.45		A
$\overline{\text{SHDN}}$ Threshold Voltage			0.4	0.6	1	V
$\overline{\text{SHDN}}$ Input Current	$V_{\overline{\text{SHDN}}} = V_{IN}$ or V_{OUT}			0.01	1	μA

ELECTRICAL CHARACTERISTICS (LTC3525-3.3)

The ● denotes the specifications which apply over the full operating junction temperature range, otherwise specifications are at $T_A = 25^\circ\text{C}$. $V_{IN} = 1.2\text{V}$, $V_{\overline{\text{SHDN}}} = 1.2\text{V}$, $V_{OUT} = 3.3\text{V}$ unless otherwise noted. (Note 2)

PARAMETER	CONDITIONS		MIN	TYP	MAX	UNITS
Input Start-Up Voltage				0.85	1	V
Output Voltage	(Note 6)	●	3.20	3.30	3.40	V
Quiescent Current, V_{OUT}	$\overline{\text{SHDN}} = V_{IN}$ (Note 4)			7	15	μA
Quiescent Current, V_{IN}	$\overline{\text{SHDN}} = V_{IN}$ (Note 4)			0.5	3	μA
Quiescent Current, V_{IN} – Shutdown	$\overline{\text{SHDN}} = 0\text{V}$, $V_{OUT} = 0\text{V}$ Not Including Switch Leakage			0.1	1	μA
NMOS Switch Leakage Current	$V_{IN} = V_{OUT} = V_{SW} = 5\text{V}$, $\overline{\text{SHDN}} = 0\text{V}$			0.1	1	μA
PMOS Switch Leakage Current	$V_{IN} = V_{SW} = 5\text{V}$, $V_{OUT} = 0\text{V}$, $\overline{\text{SHDN}} = 0\text{V}$			0.1	3	μA
NMOS Switch On-Resistance	(Note 3)			0.5		Ω
PMOS Switch On-Resistance	(Note 3)			0.8		Ω
Peak Current Limit			0.4	0.45		A
$\overline{\text{SHDN}}$ Threshold Voltage			0.4	0.6	1	V
$\overline{\text{SHDN}}$ Input Current	$V_{\overline{\text{SHDN}}} = V_{IN}$ or V_{OUT}			0.01	1	μA

LTC3525-3/ LTC3525-3.3/LTC3525-5

(LTC3525-5)

The ● denotes the specifications which apply over the full operating junction temperature range, otherwise specifications are at $T_A = 25^\circ\text{C}$. $V_{IN} = 2.4\text{V}$, $V_{SHDN} = 2.4\text{V}$, $V_{OUT} = 5\text{V}$ unless otherwise noted. (Note 2)

PARAMETER	CONDITIONS	MIN	TYP	MAX	UNITS
Input Start-Up Voltage			0.85	1	V
Output Voltage	(Note 6)	● 4.85	5.00	5.15	V
Quiescent Current, V_{OUT}	$\overline{\text{SHDN}} = V_{IN}$ (Note 4)		8	18	μA
Quiescent Current, V_{IN}	$\overline{\text{SHDN}} = V_{IN}$ (Note 4)		1.5	5	μA
Quiescent Current, V_{IN} – Shutdown	$\overline{\text{SHDN}} = 0\text{V}$, $V_{OUT} = 0\text{V}$ Not Including Switch Leakage		0.1	1	μA
NMOS Switch Leakage Current	$V_{IN} = V_{OUT} = V_{SW} = 5\text{V}$, $\overline{\text{SHDN}} = 0\text{V}$		0.1	1	μA
PMOS Switch Leakage Current	$V_{IN} = V_{SW} = 5\text{V}$, $V_{OUT} = 0\text{V}$, $\overline{\text{SHDN}} = 0\text{V}$		0.1	3	μA
NMOS Switch On-Resistance	(Note 3)		0.4		Ω
PMOS Switch On-Resistance	(Note 3)		0.7		Ω
Peak Current Limit		0.4	0.5		A
$\overline{\text{SHDN}}$ Threshold Voltage		0.4	0.6	1	V
$\overline{\text{SHDN}}$ Input Current	$V_{SHDN} = V_{IN}$ or V_{OUT}		0.01	1	μA

Note 1: Stresses beyond those listed under Absolute Maximum Ratings may cause permanent damage to the device. Exposure to any Absolute Maximum Rating condition for extended periods may affect device reliability and lifetime.

Note 2: The LTC3525 is tested under pulsed load conditions such that $T_J \approx T_A$. The LTC3525E is guaranteed to meet performance specifications from 0°C to 85°C . Specifications over the -40°C to 85°C operating junction temperature range are assured by design, characterization and correlation with statistical process controls. The LTC3525I is guaranteed over the -40°C to 125°C operating junction temperature range. Note that the maximum ambient temperature consistent with these specifications is determined by specific operating conditions in conjunction with board layout, the rated package thermal impedance and other environmental

factors. T_J is calculated from the ambient temperature T_A and power dissipation P_D according to the following formula:

$$T_J = T_A + (P_D \cdot 150^\circ\text{C/W})$$

Note 3: Specification is guaranteed by design and not 100% tested in production.

Note 4: Current Measurements are performed when the LTC3525 is not switching.

Note 5: This IC includes overtemperature protection that is intended to protect the device during momentary overload conditions. Junction temperature will exceed 125°C when overtemperature protection is active. Continuous operation above the specified maximum operating junction temperature may impair device reliability.

Note 6: Consult LTC Marketing for other output voltage options.

TYPICAL PERFORMANCE CHARACTERISTICS $T_A = 25^\circ\text{C}$ unless otherwise noted.

Maximum Output Current vs V_{IN}
(for V_{OUT} to Drop 2.5%)

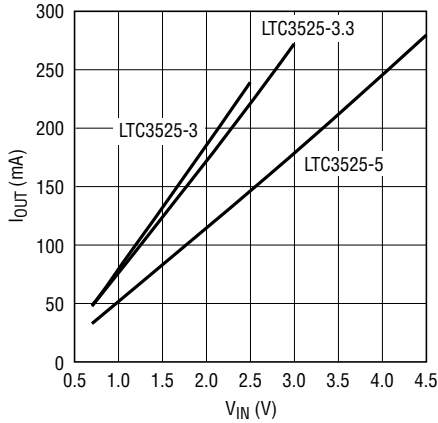

3525 G01

Maximum Startup Load vs V_{IN}
(Resistive Load)

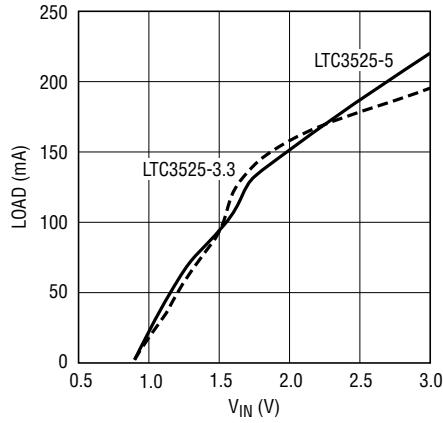

3525 G02

No-Load Input Current vs V_{IN}

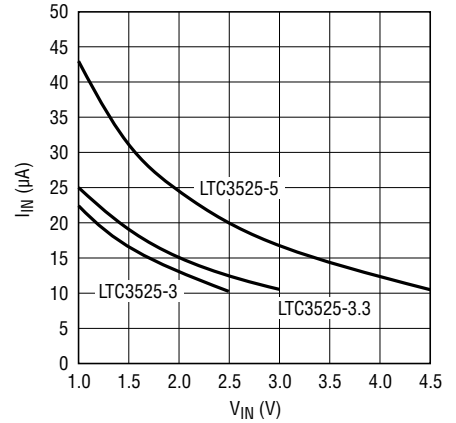

3525 G03

LTC3525-3 Efficiency and Power Loss vs Load

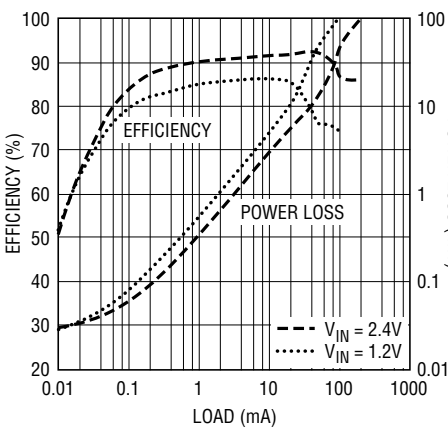

3525 G04

LTC3525-3.3 Efficiency and Power Loss vs Load

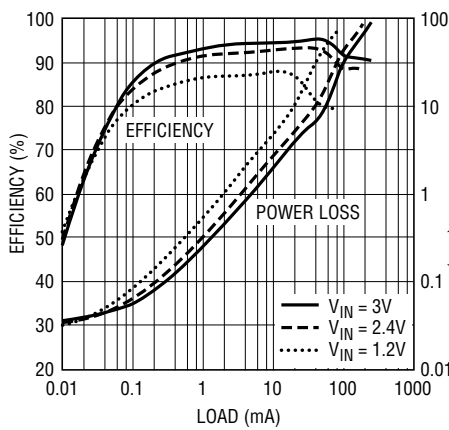

3525 G04

LTC3525-5 Efficiency and Power Loss vs Load

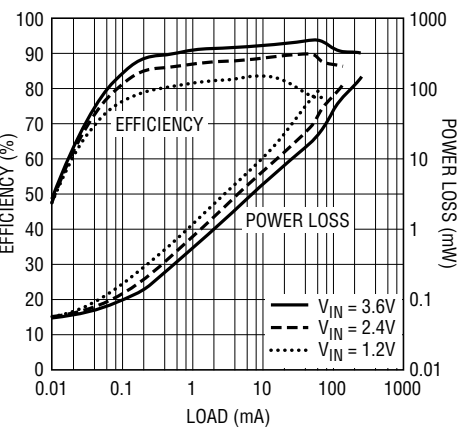

3525 G05

LTC3525-3.3 Load Regulation

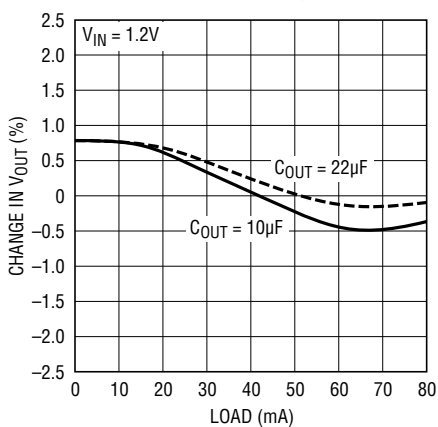

3525 G06

LTC3525-3.3 Load Regulation

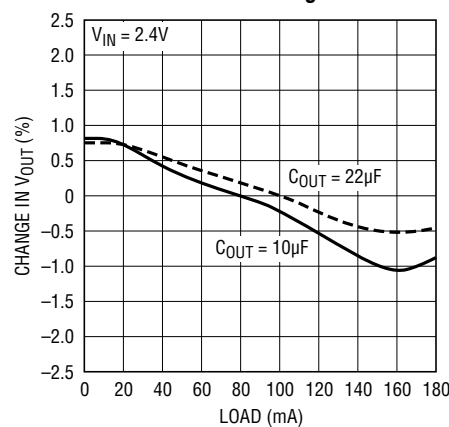

3525 G07

LTC3525-5 Load Regulation

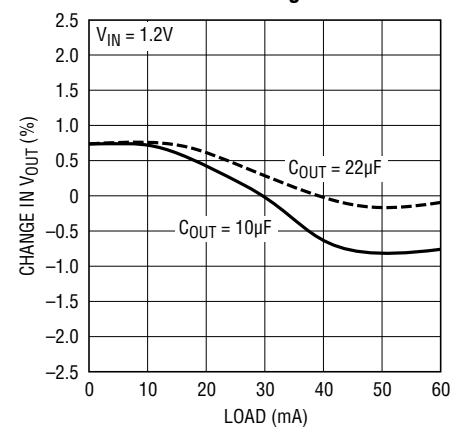

3525 G08

LTC3525-3/ LTC3525-3.3/LTC3525-5

TYPICAL PERFORMANCE CHARACTERISTICS $T_A = 25^\circ\text{C}$ unless otherwise noted.

LTC3525-5 Load Regulation

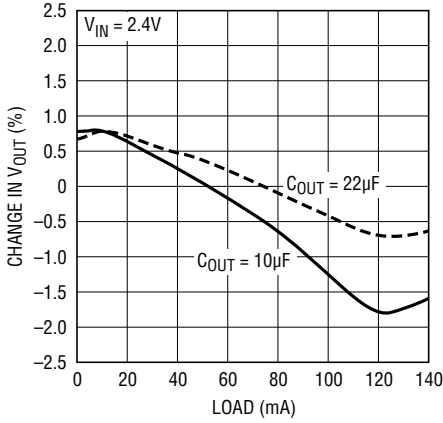

LTC3525-5 Load Regulation

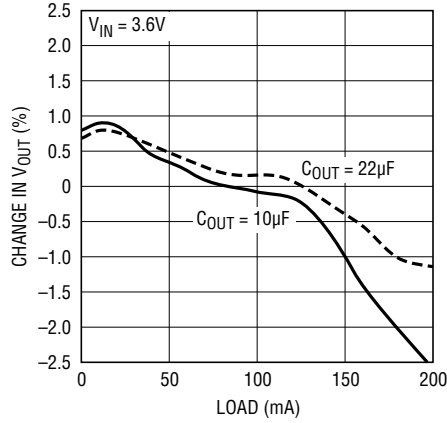

Switching Frequency vs V_{IN}

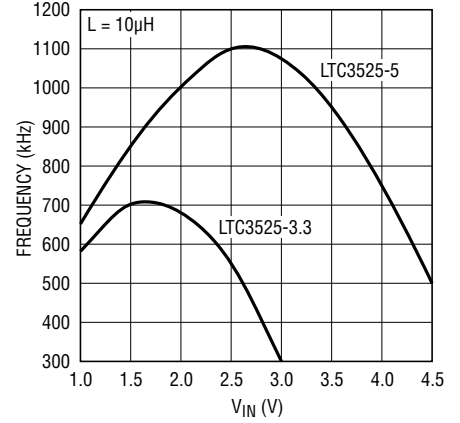

Light Load Burst Frequency vs Load

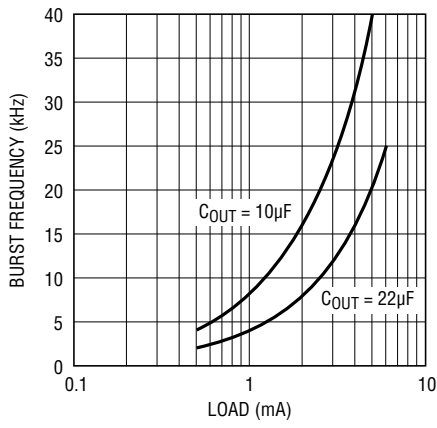

V_{OUT} Variation vs Temperature (Normalized to 25°C)

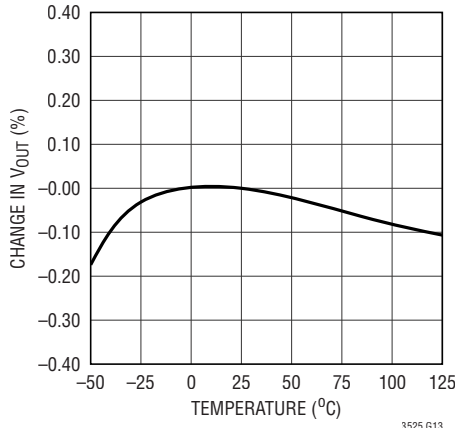

Startup Delay Coming Out of Shutdown

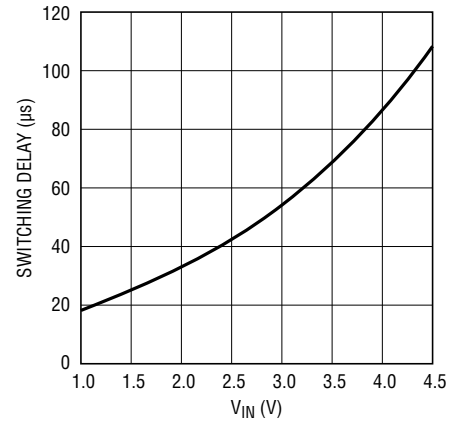

LTC3525-3.3 Input Current and V_{OUT} at Start-Up

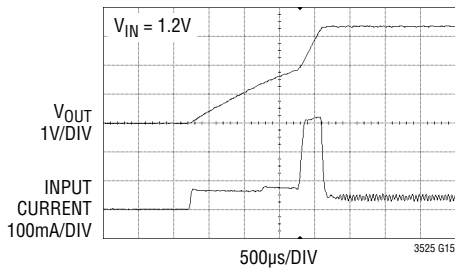

LTC3525-3.3 Output Voltage Ripple

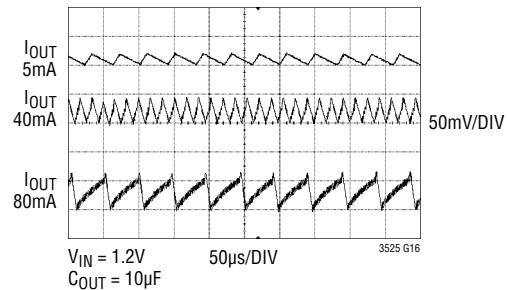

TYPICAL PERFORMANCE CHARACTERISTICS $T_A = 25^\circ\text{C}$ unless otherwise noted.

LTC3525-3.3 Output Voltage Ripple

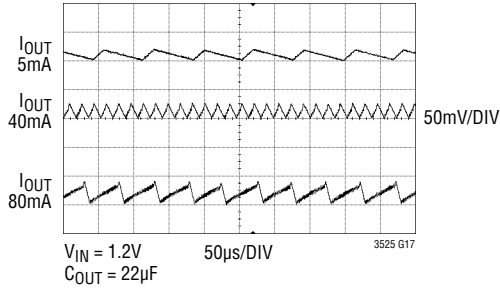

LTC3525-3.3 Output Voltage Ripple

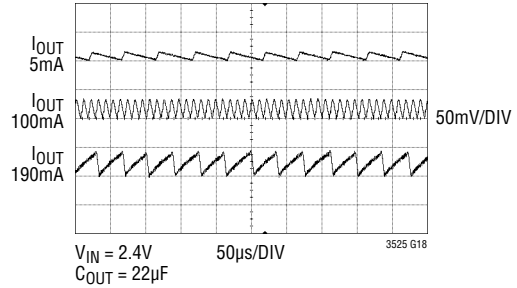

LTC3525-5 Output Voltage Ripple

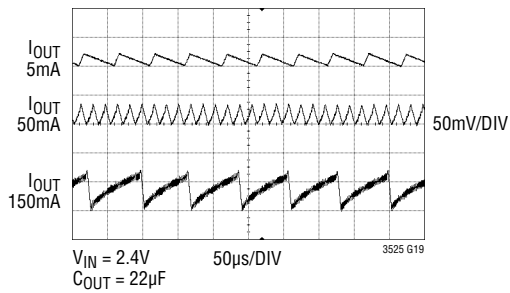

LTC3525-5 Output Voltage Ripple

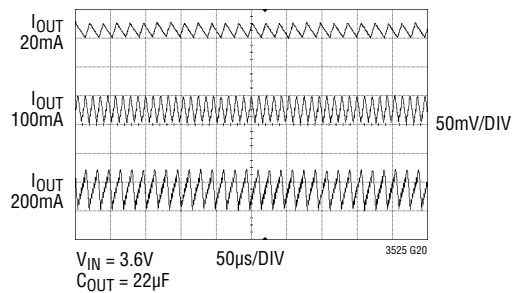

LTC3525-3.3 50mA Load Step Response

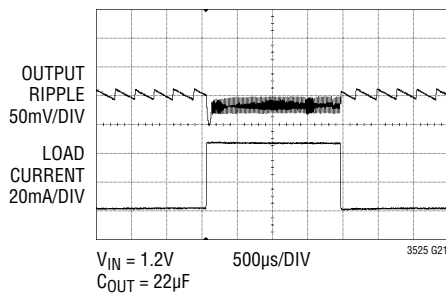

LTC3525-3.3 100mA Load Step Response

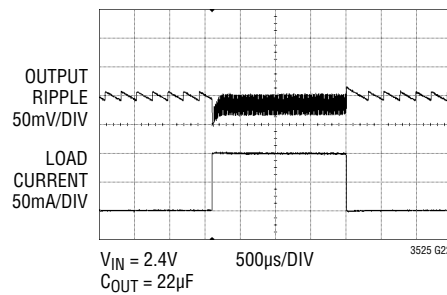

LTC3525-5 100mA Load Step Response

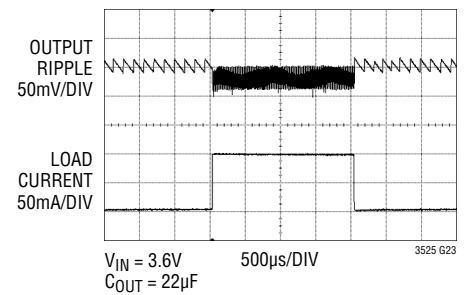

PIN FUNCTIONS

$\overline{\text{SHDN}}$ (Pin 1): Logic-Controlled Shutdown Input. Connect to a voltage $>1\text{V}$ to enable the LTC3525. Connect to a voltage $<0.4\text{V}$ to disable the LTC3525.

GND (Pins 2, 5): Ground.

V_{IN} (Pin 3): Input Voltage. The LTC3525 is powered from V_{IN} until V_{OUT} exceeds V_{IN} . Once V_{OUT} is greater than ($V_{\text{IN}} + 0.2\text{V}$ typical), it is powered from V_{OUT} . Place a ceramic bypass capacitor from V_{IN} to GND. A minimum value of $1\mu\text{F}$ is recommended.

V_{OUT} (Pin 4): Output Voltage Sense and the Output of the Synchronous Rectifier. Connect the output filter capacitor from V_{OUT} to GND, close to the IC. A minimum value of $10\mu\text{F}$ ceramic is recommended. Use $22\mu\text{F}$ for reduced output ripple. The output disconnect feature disconnects V_{OUT} from V_{IN} when $\overline{\text{SHDN}}$ is $<0.4\text{V}$.

SW (Pin 6): Switch Pin. Connect an inductor from this pin to V_{IN} . An internal antiringing resistor is connected across SW and V_{IN} after the inductor current has dropped to zero to minimize EMI.

BLOCK DIAGRAM

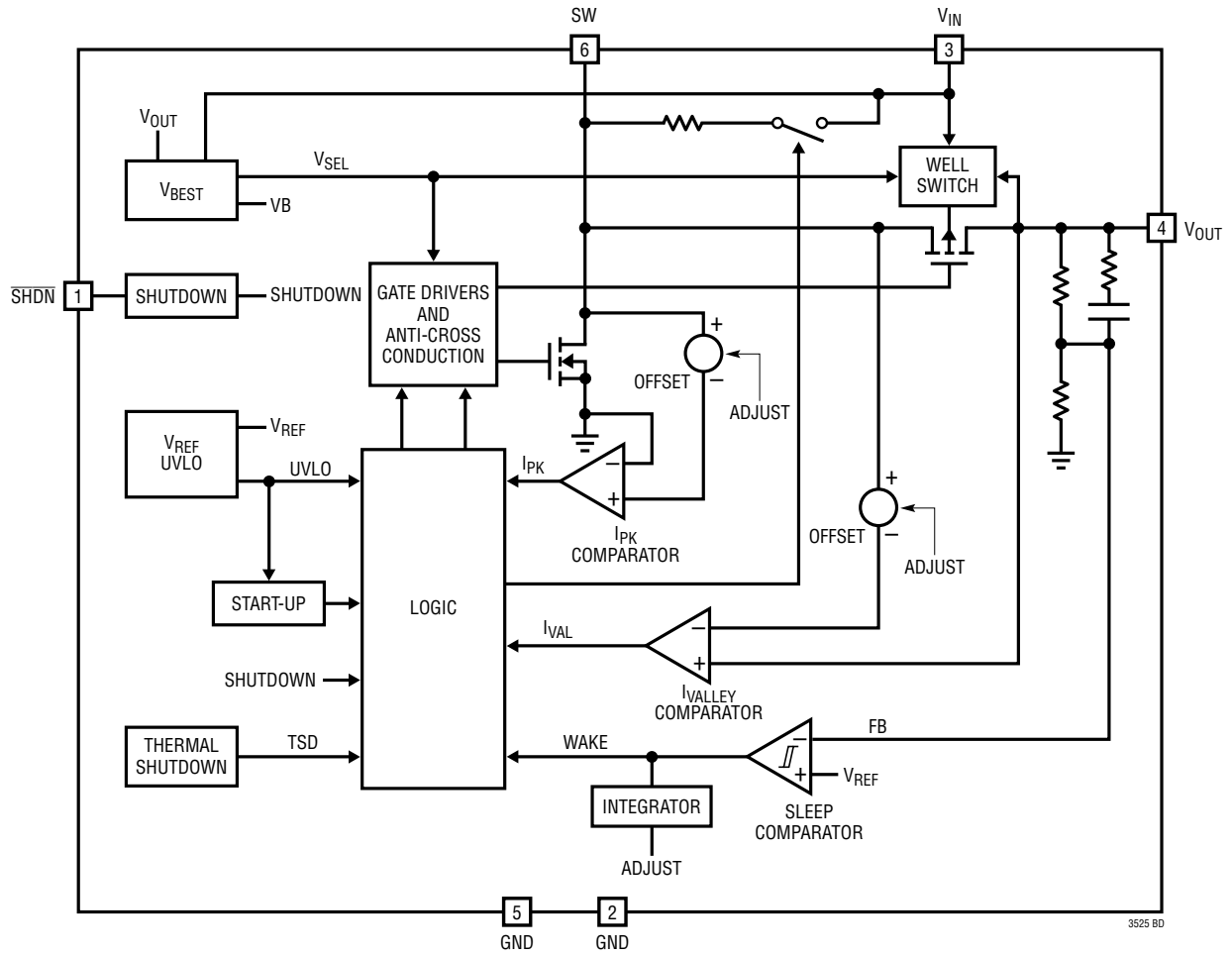

3525 BD

OPERATION

The LTC3525 is a high performance Burst Mode operation only, synchronous boost converter requiring only three small external components. Its simplicity and small size make it a high efficiency alternative to charge pump designs. It is designed to start up from a single alkaline or nickel cell, with input voltages as low as 1V, or from two or three cells (or a Li-Ion battery), with voltages as high as 4.5V. Once started, V_{IN} can be as low as 0.5V (depending on load current) and maintain regulation. The output voltage is preset internally to either 3V, 3.3V or 5V. Peak switch current is 400mA minimum, providing regulation with load currents up to 150mA, depending on input voltage.

Synchronous rectification provides high efficiency operation while eliminating the need for an external Schottky diode. True output disconnect eliminates inrush current at start-up, and allows V_{OUT} to be disconnected from V_{IN} , for zero shutdown current.

The output disconnect feature also allows the LTC3525 to maintain regulation with an input voltage equal to or greater than V_{OUT} . Note, however, that the synchronous rectifier is not enabled in this mode resulting in lower efficiency and reduced output current capability.

The operating quiescent current is only 7 μ A typical, allowing the converter to maintain high efficiency at extremely light loads.

Shutdown

The LTC3525 is shut down by pulling \overline{SHDN} below 0.4V, and made active by raising it above 1V. Although \overline{SHDN} can be driven above V_{IN} or V_{OUT} (up to the absolute maximum rating) without damage, the LTC3525 has a proprietary test mode that may be engaged if \overline{SHDN} is held in the range of 0.5V to 1V higher than the greater of V_{IN} or V_{OUT} . If the test mode is engaged, normal PWM switching action is interrupted, which can cause undesirable operation in some applications. Therefore, in applications where \overline{SHDN} may be driven above V_{IN} , a resistor divider or other means must be employed to keep the \overline{SHDN} voltage below $(V_{IN} + 0.4V)$ to prevent the possibility of the test mode being engaged. Please refer to Figure 1 for two possible implementations.

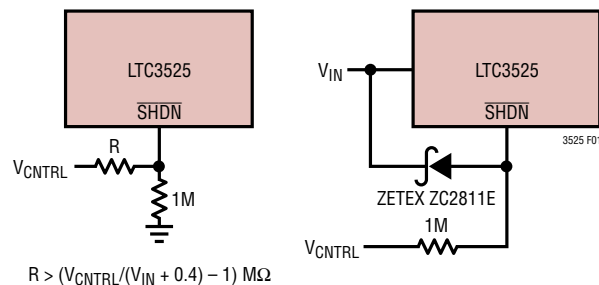

Figure 1

After the \overline{SHDN} pin rises, there is a short delay before switching starts. The delay is 20 μ s to 120 μ s, depending on input voltage (see Typical Performance Characteristics curve).

Start-Up

A start-up oscillator allows the LTC3525 to start with input voltages as low as 1V. It remains in start-up mode until two conditions are met. V_{OUT} must exceed V_{IN} by at least 0.2V typical and either V_{IN} or V_{OUT} must be greater than 1.8V typical.

During start-up, the synchronous rectifier is not enabled, and the internal P-channel synchronous rectifier acts as a follower, causing the peak voltage on SW to reach $(V_{IN} + 1V)$ typical. This limits inrush current by maintaining control of the inductor current when V_{OUT} is less than V_{IN} . To reduce power dissipation in the P-channel synchronous rectifier when the output is shorted, a foldback feature is incorporated that reduces the peak inductor current when V_{IN} is more than 1.7V greater than V_{OUT} .

Normal Operation

Once V_{OUT} has increased more than 0.2V typical above V_{IN} , and either voltage is above 1.8V, normal operation begins, with synchronous rectification enabled. In this mode, the internal N-channel MOSFET connected between SW and GND stays on until the inductor current reaches a maximum peak value, after which it is turned off and the P-channel synchronous rectifier is turned on. It stays on, delivering current to the output, until the inductor current has dropped below a minimum value at

OPERATION

which point it turns off and the cycle repeats. When the output voltage reaches its regulated value both switches are turned off and the LTC3525 goes to sleep, during which time the output capacitor supplies current to the load. Once the output voltage drops approximately 9mV below the regulation value the IC leaves sleep mode and switching is resumed.

The LTC3525 has been designed for low output voltage ripple. The output voltage ripple is typically only 20mV peak-to-peak at light load and 60mV peak-to-peak at full load using the minimum recommended 10µF output capacitor for the LTC3525-3.3 and a 22µF capacitor for the LTC3525-5 (due to the capacitor's DC bias effect). An antiring circuit damps any oscillation at the switch node when the inductor current falls to zero.

Power Adjust Feature

The LTC3525 incorporates a feature that maximizes efficiency at light load while providing increased power capability at heavy load by adjusting the peak and valley of the inductor current as a function of load. Lowering the peak inductor current to 150mA at light load optimizes efficiency by reducing conduction losses in the internal MOSFET switches. As the load increases, the peak inductor current is automatically increased to a maximum of 400mA. At intermediate loads, the peak inductor current may vary

from 150mA to 400mA. Figure 2 shows an example of how the inductor current changes as the load increases. Please note that output capacitor values greater than 47µF will result in higher peak currents than necessary at light load. This will lower the light load efficiency.

The valley of the inductor current is automatically adjusted as well, to maintain a relatively constant inductor ripple current. This keeps the switching frequency relatively constant.

The maximum average load current that can be supported is given by:

$$I_{O(MAX)} = \frac{0.3 \cdot V_{IN} \cdot \eta}{V_O} \text{ Amps}$$

where η is the efficiency (see Typical Performance Characteristics).

The “burst” frequency (how often the LTC3525 delivers a burst of current pulses to the load) is determined by the internal hysteresis (output voltage ripple), the load current and the amount of output capacitance. All Burst Mode operation or hysteretic converters will enter the audible frequency range when the load is light enough. However, due to the low peak inductor current at light load, circuits using the LTC3525 do not typically generate any audible noise.

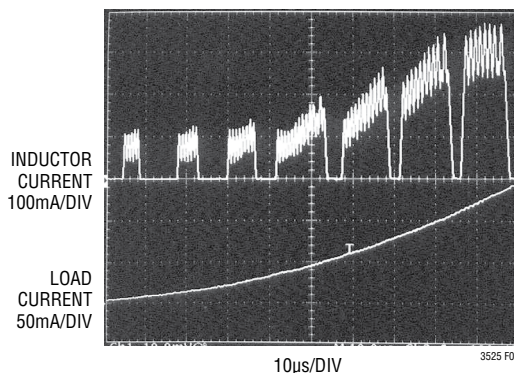

Figure 2. Inductor Current Changing as a Function of Load

OPERATION

Component Selection

Inductor values between 4.7 μ H and 15 μ H are recommended. In most applications 10 μ H will yield the best compromise between size and efficiency. The inductor should be a low loss ferrite design and must be rated for peak currents of at least 400mA without saturating. Inductors with lower DC resistance will improve efficiency. Note that the inductor value does not have a significant effect on ripple current, so while lower values will increase the operating frequency, they do not reduce output voltage ripple.

Some recommended inductor examples are Murata LQH32C and Coilcraft LPO4812, LPO3310, DO3314, DS1608 and MSS4020.

A ceramic input bypass capacitor should be located as close as possible to the V_{IN} and GND pins of the IC. A minimum value of 1 μ F is recommended. If the battery is more than a few inches away, a bulk tantalum decoupling cap of at least 10 μ F is recommended on V_{IN} .

The output capacitor should also be a ceramic, located close to the V_{OUT} and GND pins. A minimum value of 10 μ F is recommended. Increasing the value of the output capacitor to 22 μ F will result in lower output ripple. Higher capacitor values will only offer a small reduction in output ripple, while reducing light load efficiency by causing the peak inductor current to increase above its minimum value of 150mA. The input and output capacitors should be X5R or X7R types, not Y5V.

Table 1. Inductor Vendor Information

SUPPLIER	PHONE	FAX	WEBSITE
Murata	USA: (814) 237-1431	USA: (814) 238-0490	www.murata.com
Coilcraft	(847) 639-6400	(847) 639-1469	www.coilcraft.com
Sumida	USA: (847) 956-0666	USA: (847) 956-0702	www.sumida.com
Taiyo Yuden	(408) 573-4150	(408) 573-4159	www.t-yuden.com
TOKO	(847) 297-0070	(847) 699-7864	www.toko.co.jp/products/en
TDK	(847) 699-2299	(847) 803-6296	www.tdk.com
Würth	(605) 886-4385	(605) 886-4486	www.we-online.com

Table 2. Capacitor Vendor Information

SUPPLIER	PHONE	FAX	WEBSITE
Murata	USA: (814) 237-1431	USA: (814) 238-0490	www.murata.com
Taiyo Yuden	(408) 573-4150	(408) 573-4159	www.t-yuden.com
TDK	(847) 803-6100	(847) 803-6296	www.component.tdk.com
AVX	(803) 448-9411	(803) 448-1943	www.avxcorp.com

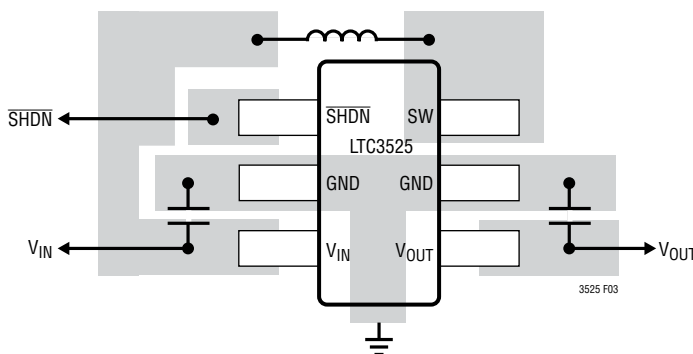
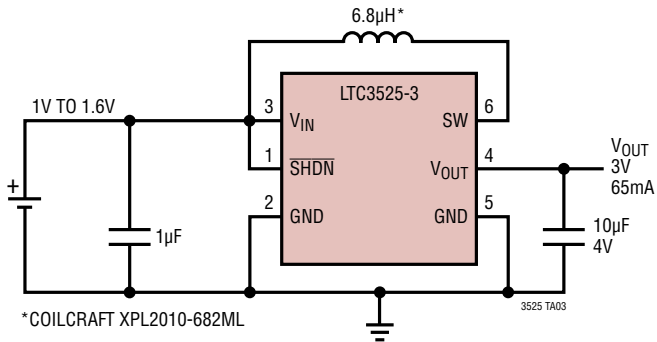

Figure 3. Recommended Component Placement

TYPICAL APPLICATIONS

Single Cell to 3V Converter Using 1mm High Monolithic Inductor



Single Alkaline or NiMH to 3.3V Converter with 1mm Profile

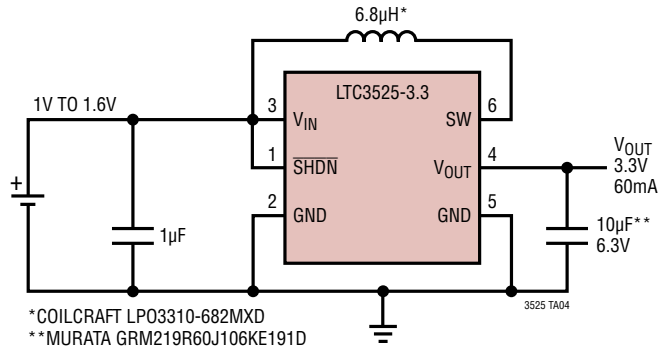

2-Alkaline or NiMH to 3.3V

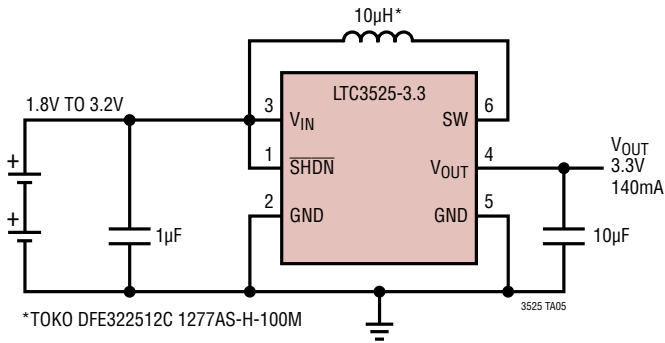

Li-Ion to 5V

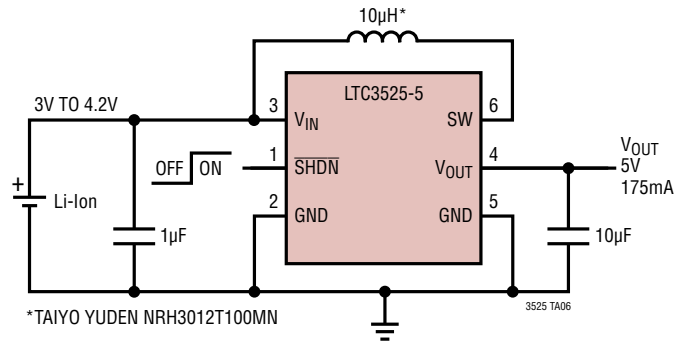

PACKAGE DESCRIPTION

SC6 Package
6-Lead Plastic SC70
(Reference LTC DWG # 05-08-1638 Rev B)

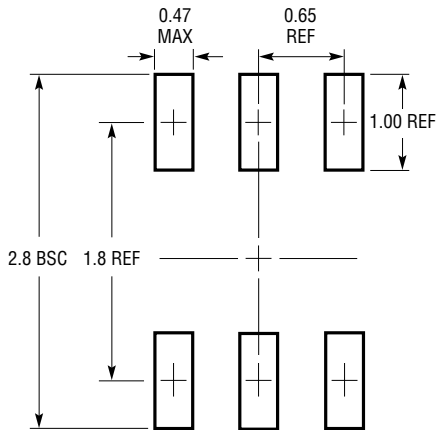

RECOMMENDED SOLDER PAD LAYOUT
PER IPC CALCULATOR

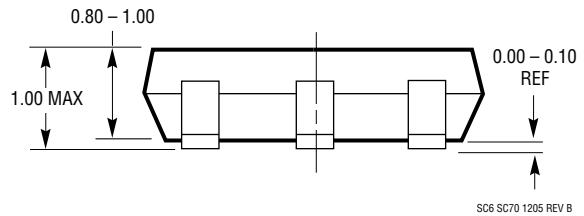
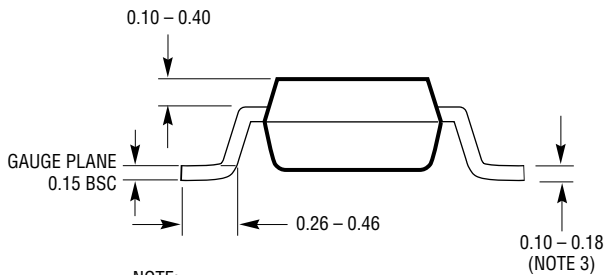
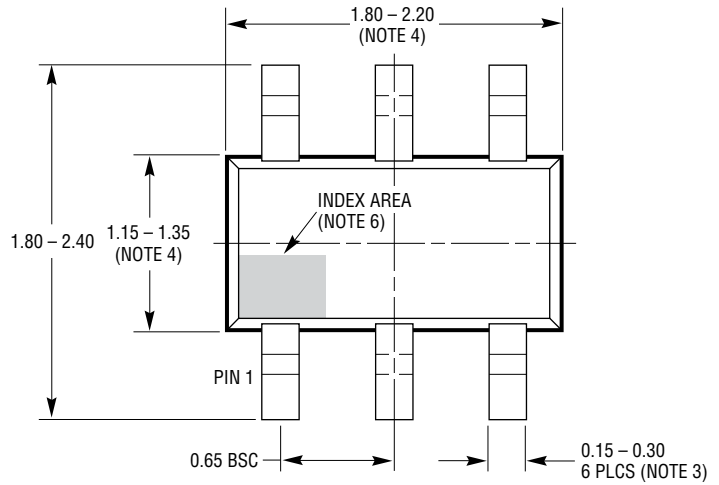

SC6 SC70 1205 REV B

- NOTE:
1. DIMENSIONS ARE IN MILLIMETERS
 2. DRAWING NOT TO SCALE
 3. DIMENSIONS ARE INCLUSIVE OF PLATING
 4. DIMENSIONS ARE EXCLUSIVE OF MOLD FLASH AND METAL BURR

5. MOLD FLASH SHALL NOT EXCEED 0.254mm
6. DETAILS OF THE PIN 1 IDENTIFIER ARE OPTIONAL, BUT MUST BE LOCATED WITHIN THE INDEX AREA
7. EIAJ PACKAGE REFERENCE IS EIAJ SC-70
8. JEDEC PACKAGE REFERENCE IS MO-203 VARIATION AB

REVISION HISTORY (Revision history begins at Rev B)

REV	DATE	DESCRIPTION	PAGE NUMBER
B	09/10	Updated "Shutdown" section	8
C	04/15	Changed input starting voltage from 1V to 0.85V	1
		Added table to reference other LTC3525 family parts	1
		Changed Operating Temperature Range to Operating Junction Temperature Range and changed the Operating Junction Temperature Range from 85°C to 125°C in the Absolute Maximum Ratings section	2
		Updated Order Information table	2
		Changed Operating Temperature Range to Operating Junction Temperature Range and added Note 2 to the Electrical Characteristics section	3, 4
		Updated Note 2 for addition of I Grade	4
		Updated V _{OUT} Variation vs Temperature curve	6
		Updated Inductor Vendor Information in Table 1	12
		Updated Inductor Information	13
		Updated title and inductor vendor in the Typical Application section	16
		Modified Related Parts table	16

LTC3525-3/ LTC3525-3.3/LTC3525-5

TYPICAL APPLICATION

3.3V TO 5V Converter with 1.2mm Profile

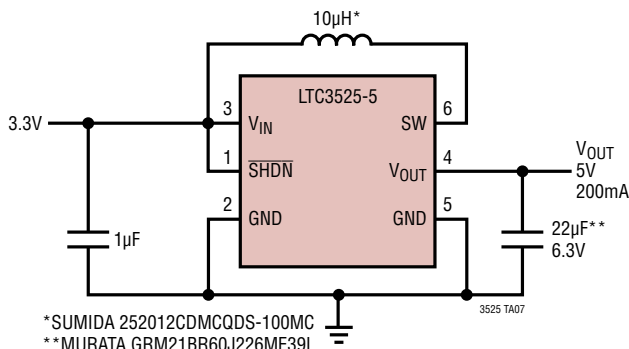

RELATED PARTS

PART NUMBER	DESCRIPTION	COMMENTS
LTC1751-3.3/ LTC1751-5	100mA, 800kHz, Micropower, Regulated Charge Pump DC/DC Converters	V_{IN} : 2.5V to 5.5V, $V_{OUT(MAX)}$ = 3.3V/5V, I_Q = 20µA, I_{SD} < 1µA, MS8 Package
LTC3200-5	100mA, 2MHz, Regulated 5V Charge Pump	V_{IN} : 2.7V to 4.5V, $V_{OUT(MAX)}$ = 5V, I_Q = 2mA, I_{SD} < 1µA, ThinSOT Package
LTC3400/LTC3400B	600mA (I_{SW}), 1.2MHz, Synchronous Step-Up DC/DC Converter	92% Efficiency, V_{IN} : 0.5V to 5V, $V_{OUT(MAX)}$ = 5V, I_Q = 19µA/300µA, I_{SD} < 1µA, ThinSOT Package
LTC3401	1A (I_{SW}), 3MHz, Synchronous Step-Up DC/DC Converter	97% Efficiency, V_{IN} : 0.5V to 5V, $V_{OUT(MAX)}$ = 5.5V, I_Q = 38µA, I_{SD} < 1µA, MS Package
LTC3402	2A (I_{SW}), 3MHz, Synchronous Step-Up DC/DC Converter	97% Efficiency, V_{IN} : 0.5V to 5V, $V_{OUT(MAX)}$ = 5.5V, I_Q = 38µA, I_{SD} < 1µA, MS Package
LTC3421	3A (I_{SW}), 3MHz, Synchronous Step-Up DC/DC Converter with Output Disconnect	95% Efficiency, V_{IN} : 0.5V to 4.5V, $V_{OUT(MAX)}$ = 5.25V, I_Q = 12µA, I_{SD} < 1µA, QFN-24 Package
LTC3425	5A (I_{SW}), 8MHz, 4-Phase Synchronous Step-Up DC/DC Converter with Output Disconnect	95% Efficiency, V_{IN} : 0.5V to 4.5V, $V_{OUT(MAX)}$ = 5.25V, I_Q = 12µA, I_{SD} < 1µA, QFN-32 Package
LTC3429/LTC3429B	600mA, 500kHz Single/Dual Cell Micropower Synchronous Boost Converter with Output Disconnect	95% Efficiency, V_{IN} : 1V to 4.5V, $V_{OUT(MAX)}$ = 5V, I_Q = 20µA, I_{SD} < 1µA, SC70 Package
LTC3458	1.4A (I_{SW}), 1.5MHz, Synchronous Step-Up DC/DC Converter with Output Disconnect	V_{IN} : 1.5V to 6V, $V_{OUT(MAX)}$ = 7.5V, I_{SD} < 1µA, 3mm × 4mm DFN Package
LTC3458L	1.7A (I_{SW}), 1.5MHz, Synchronous Step-Up DC/DC Converter with Output Disconnect	V_{IN} : 1.5V to 6V, $V_{OUT(MAX)}$ = 6V, I_{SD} < 1µA, 3mm × 4mm DFN Package
LTC3459	60mA, 10V Micropower Synchronous Boost Converter	95% Efficiency, V_{IN} : 1.5V to 6V, $V_{OUT(MAX)}$ = 10V, I_Q = 10µA, I_{SD} < 1µA, ThinSOT Package
LT3464	85mA (I_{SW}), High Efficiency Step-Up DC/DC Converter with Integrated Schottky and PNP Disconnect	V_{IN} : 2.3V to 10V, $V_{OUT(MAX)}$ = 34V, I_Q = 25µA, I_{SD} < 1µA, ThinSOT Package
LTC3528/LTC3528B	1A, 1MHz Synchronous Step-Up DC/DC Converter with Output Disconnect	94% Efficiency, V_{IN} Start-Up Voltage: 700mV, $V_{OUT(MAX)}$ = 5.25V, I_Q = 12µA, I_{SD} < 1µA, 2mm × 3mm DFN Package
LTC3529	1.5A, 1.5MHz, Synchronous Step-Up DC/DC Converter	95% Efficiency, V_{IN} : 1.8V to 5.25V, $V_{OUT(MAX)}$ = 5.15V, I_{SD} < 1µA, 2mm × 3mm DFN Package
LTC3539/LTC3539-2	2A, 1MHz/2MHz Synchronous Step-Up DC/DC Converter	94% Efficiency, V_{IN} Start-Up Voltage: 700mV, $V_{OUT(MAX)}$ = 5.25V, I_Q = 12µA, I_{SD} < 1µA, 2mm × 3mm DFN Package

3525fc